

LINOVECTOR II

Bare Element "4"
Copper/Aluminum and
Steel Element Ratings

Submittal

Specification

Bare Element "4"

ELEMENT:

TYPE: Cu/AL (Mechanically Expanded)
 LENGTHS: 2'0" thru 12'6" in 1" Increments
 for 1" & 1-1/4" Cu.
 2'0" to 8'0" in 1" Increments
 for 3/4" Cu.

One End Flared (Std)

See Catalog for Working
Pressures

BRACKETS:

Wall Mtd B.B. Hngr

ELEMENT:

TYPE: IPS Steel (Mechanically Expanded)
 LENGTHS: 2'-0" to 12'-6" in 1" Increments
 NPT Thread both Ends (Std)
 Beveled Ends for Field Weld (Opt'l)

See Catalog for Working
Pressures

BRACKETS:

Wall Mtd B.B. Hngr

TUBE SIZE	FIN SIZE HEIGHT x WIDTH	CRADLE NUMBER	A	B
3/4 COPPER	3 5/8 x 4 1/4	2	7 9/16	6 3/4
	4 1/4 x 4 1/4	3A	7 1/4	6"
1" COPPER	3 5/8 x 4 1/4	2	7 9/16	6 9/16
	4 1/4 x 4 1/4		7 1/4	6 1/4
1 1/4 COPPER	3 5/8 x 4 1/4	2	7 9/16	6 7/16
	4 1/4 x 4 1/4		7 1/4	6 1/8
1" STEEL	4 1/4 x 4 1/4	2	7 1/4	6 1/8
1 1/4 STEEL	4 1/4 x 4 1/4	2	7 1/4	5 15/16
2" STEEL	4 1/4 x 4 1/4	1	7 1/4	6 3/16

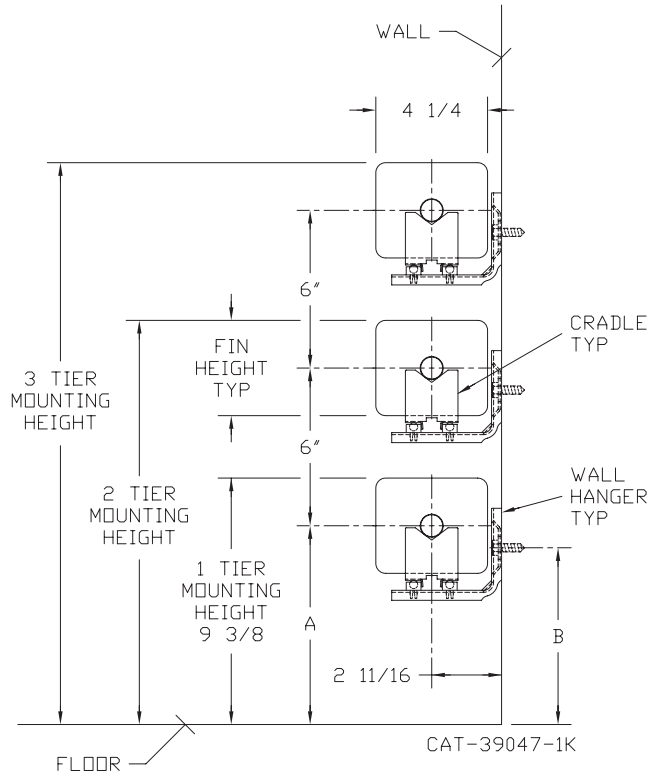

260 North Elm St., Westfield, MA 01085
 (413) 568-9571
 www.vulcanrad.com

PROJECT: _____ DATE: _____
 LOCATION: _____
 ARCHITECT: _____
 ENGINEER: _____
 CONTRACTOR: _____
 PO NUMBER: _____

STYLE "4" BARE ELEMENT

COPPER/ALUMINUM ELEMENTS

ALL RATINGS ARE IN BTU/HR/LIN FT AND BASED ON 3 FPS VELOCITY, 65° EAT

TUBE SIZE	CATALOG DESIGNATION	FIN SIZE HEIGHT X WIDTH	FINS PER FT.	FIN THICKNESS IN INCHES	TIERS AND CENTERS IN INCHES	MOUNTING HEIGHT IN INCHES	STEAM 215° FACTOR	HOT WATER (AVG.)								
								200°	190°	180°	170°	160°	150°	140°	130°	120°
								CORRECTION FACTORS FOR AVERAGE WATER TEMPERATURES								
							1.00	0.86	0.78	0.69	0.61	0.53	0.45	.40	.33	.26
3/4"	VC3/4-433	3-5/8" X 4-1/4"	32	.020	1 2-6 CL 3-6 CL	9-3/8 15-3/8 21-3/8	1210 2130 2880	1040 1830 2480	940 1660 2250	830 1470 1990	740 1300 1760	640 1130 1530	540 960 1300	480 850 1150	400 700 950	310 550 750
3/4"	VC3/4-434	3-5/8" X 4-1/4"	40	.020	1 2-6 CL 3-6 CL	9-3/8 15-3/8 21-3/8	1450 2490 3300	1250 2140 2840	1130 1940 2570	1000 1720 2280	880 1520 2010	770 1320 1750	650 1120 1490	580 1000 1320	480 820 1090	380 650 860
3/4"	VC3/4-435	3-5/8" X 4-1/4"	50	.020	1 2-6 CL 3-6 CL	9-3/8 15-3/8 21-3/8	1600 2650 3450	1380 2280 2970	1250 2070 2690	1100 1830 2380	980 1620 2100	850 1400 1830	720 1190 1550	640 1060 1380	530 870 1140	420 690 900
1"	VC433	3-5/8" X 4-1/4"	32	.020	1 2-6 CL 3-6 CL	9-3/8 15-3/8 21-3/8	1260 2220 3000	1080 1910 2580	980 1730 2340	870 1530 2070	770 1350 1830	670 1180 1590	570 1000 1350	500 890 1200	420 730 990	330 580 780
1"	VC434	3-5/8" X 4-1/4"	40	.020	1 2-6 CL 3-6 CL	9-3/8 15-3/8 21-3/8	1410 2420 3200	1210 2080 2750	1100 1890 2500	970 1670 2210	860 1480 1950	750 1280 1700	630 1090 1440	560 970 1280	470 800 1060	370 630 830
1"	VC435	3-5/8" X 4-1/4"	50	.020	1 2-6 CL 3-6 CL	9-3/8 15-3/8 21-3/8	1600 2640 3450	1380 2270 2970	1250 2060 2690	1100 1820 2380	980 1610 2100	850 1400 1830	720 1190 1550	640 1060 1380	530 870 1140	420 690 900
1-1/4"	VC1433	3-5/8" X 4-1/4"	32	.020	1 2-6 CL 3-6 CL	9-3/8 15-3/8 21-3/8	1310 2310 3130	1130 1990 2690	1020 1800 2440	900 1590 2160	800 1410 1910	690 1220 1660	590 1040 1410	520 920 1250	430 760 1030	340 600 810
1-1/4"	VC1434	3-5/8" X 4-1/4"	40	.020	1 2-6 CL 3-6 CL	9-3/8 15-3/8 21-3/8	1440 2470 3260	1240 2120 2800	1120 1930 2540	990 1700 2250	880 1510 1990	760 1310 1730	650 1110 1470	580 990 1300	480 820 1080	370 640 850
1-1/4"	VC1435	3-5/8" X 4-1/4"	50	.020	1 2-6 CL 3-6 CL	9-3/8 15-3/8 21-3/8	1600 2650 3460	1380 2280 2980	1250 2070 2700	1100 1830 2390	980 1620 2110	850 1400 1830	720 1190 1560	640 1060 1380	530 870 1140	420 690 900
3/4"	VC3/4 43	4-1/4" SQ.	32	.020	1 2-6 CL 3-6 CL	9-3/8 15-3/8 21-3/8	1340 2340 3200	1150 2010 2750	1050 1830 2500	920 1610 2210	820 1430 1950	710 1240 1700	600 1050 1440	540 940 1280	440 770 1060	350 610 830
3/4"	VC3/4 44	4-1/4" SQ.	40	.020	1 2-6 CL 3-6 CL	9-3/8 15-3/8 21-3/8	1600 2540 3330	1380 2180 2860	1250 1980 2600	1100 1750 2300	980 1550 2030	850 1350 1760	720 1140 1500	640 1020 1330	530 840 1100	420 660 870
3/4"	VC3/4 45	4-1/4" SQ.	50	.020	1 2-6 CL 3-6 CL	9-3/8 15-3/8 21-3/8	1650 2620 3430	1420 2250 2950	1290 2040 2680	1140 1810 2370	1010 1600 2090	870 1390 1820	740 1180 1540	660 1050 1370	540 860 1130	430 680 890
1"	VC43	4-1/4" SQ.	32	.020	1 2-6 CL 3-6 CL	9-3/8 15-3/8 21-3/8	1340 2370 3230	1150 2040 2780	1050 1850 2520	920 1640 2230	820 1450 1970	710 1260 1710	600 1070 1450	540 950 1290	440 780 1070	350 620 840
1"	VC44	4-1/4" SQ.	40	.020	1 2-6 CL 3-6 CL	9-3/8 15-3/8 21-3/8	1490 2490 3320	1280 2140 2860	1160 1940 2590	1030 1720 2290	910 1520 2030	790 1320 1760	670 1120 1490	600 1000 1330	490 820 1100	390 650 860
1"	VC45	4-1/4" SQ.	50	.020	1 2-6 CL 3-6 CL	9-3/8 15-3/8 21-3/8	1680 2650 3460	1440 2280 2980	1310 2070 2700	1160 1830 2390	1020 1620 2110	890 1400 1830	760 1190 1560	670 1060 1380	550 870 1140	440 690 900
1-1/4"	VC143	4-1/4" SQ.	32	.020	1 2-6 CL 3-6 CL	9-3/8 15-3/8 21-3/8	1400 2470 3360	1200 2120 2890	1090 1930 2620	970 1700 2320	850 1510 2050	740 1310 1780	630 1110 1510	560 990 1340	460 820 1110	360 640 870
1-1/4"	VC144	4-1/4" SQ.	40	.020	1 2-6 CL 3-6 CL	9-3/8 15-3/8 21-3/8	1660 2680 3490	1430 2300 3000	1290 2090 2720	1150 1850 2410	1010 1630 2130	880 1420 1850	750 1210 1570	660 1070 1400	550 880 1150	430 700 910
1-1/4"	VC145	4-1/4" SQ.	50	.020	1 2-6 CL 3-6 CL	9-3/8 15-3/8 21-3/8	1710 2460 3200	1470 2120 2750	1330 1920 2500	1180 1700 2210	1040 1500 1950	910 1300 1700	770 1110 1440	680 980 1280	560 810 1060	440 640 830

Note: Copper tube furnished flared one end standard.

STYLE "4" BARE ELEMENT

STEEL ELEMENTS

ALL RATINGS ARE IN BTU/HR/LIN FT AND BASED ON 3 FPS VELOCITY, 65° EAT

TUBE SIZE	CATALOG DESIGNATION	FIN SIZE HEIGHT X WIDTH	FINS PER FT.	FIN THICKNESS IN INCHES	TIERS AND CENTERS IN INCHES	MOUNTING HEIGHT IN INCHES	STEAM 215° FACTOR	HOT WATER (AVG.)								
								200°	190°	180°	170°	160°	150°	140°	130°	120°
								CORRECTION FACTORS FOR AVERAGE WATER TEMPERATURES								
					1	9-3/8	1.00	0.86	0.78	0.69	0.61	0.53	0.45	.40	.33	.26
1"	VS43	4-1/4" SQ.	32	.032	2-6 CL	15-3/8	1320	1140	1030	910	810	700	590	530	440	340
					3-6 CL	21-3/8	2320	2000	1810	1600	1420	1230	1040	930	770	600
					1	9-3/8	1490	1280	1160	1030	910	790	670	600	490	390
1"	VS44	4-1/4" SQ.	40	.032	2-6 CL	15-3/8	2450	2110	1910	1690	1490	1300	1100	980	810	640
					3-6 CL	21-3/8	3180	2730	2480	2190	1940	1690	1430	1270	1050	830
1"	VS45	4-1/4" SQ.	50	.032	1	9-3/8	1580	1360	1230	1090	960	840	710	630	520	410
					2-6 CL	15-3/8	2510	2160	1960	1730	1530	1330	1130	1000	830	650
					3-6 CL	21-3/8	3230	2780	2520	2230	1970	1710	1450	1290	1070	840
1-1/4"	VS143	4-1/4" SQ.	32	.032	1	9-3/8	1220	1050	950	840	740	650	550	490	400	320
					2-6 CL	15-3/8	2300	1980	1790	1590	1400	1220	1040	920	760	600
					3-6 CL	21-3/8	3030	2610	2360	2090	1850	1610	1360	1210	1000	790
1-1/4"	VS144	4-1/4" SQ.	40	.032	1	9-3/8	1480	1270	1150	1020	900	780	670	590	490	380
					2-6 CL	15-3/8	2440	2100	1900	1680	1490	1290	1100	980	810	630
					3-6 CL	21-3/8	3170	2730	2470	2190	1930	1680	1430	1270	1050	820
1-1/4"	VS145	4-1/4" SQ.	50	.032	1	9-3/8	1550	1330	1210	1070	950	820	700	620	510	400
					2-6 CL	15-3/8	2460	2120	1920	1700	1500	1300	1110	980	810	640
					3-6 CL	21-3/8	3200	2750	2500	2210	1950	1700	1440	1280	1060	830
2"	VS242	4-1/4" SQ.	25	.032	1	9-3/8	1140	980	890	790	700	600	510	460	380	300
					2-6 CL	15-3/8	2030	1750	1580	1400	1240	1080	910	810	670	530
					3-6 CL	21-3/8	2700	2320	2110	1860	1650	1430	1220	1080	890	700
2"	VS243	4-1/4" SQ.	32	.032	1	9-3/8	1320	1140	1030	910	810	700	590	530	440	340
					2-6 CL	15-3/8	2230	1920	1740	1540	1360	1180	1000	890	740	580
					3-6 CL	21-3/8	2910	2500	2270	2010	1780	1540	1310	1160	960	760
2"	VS244	4-1/4" SQ.	40	.032	1	9-3/8	1490	1280	1160	1030	910	790	670	600	490	390
					2-6 CL	15-3/8	2360	2030	1840	1630	1440	1250	1060	940	780	610
					3-6 CL	21-3/8	3040	2610	2370	2100	1850	1610	1370	1220	1000	790

- Notes: 1) Steel fins furnished as .032 thick, painted black.
 2) NPT threads furnished on steel elements. Please use domestic fittings for proper installation.
 3) The ends can be provided chamfered for field welded fittings when specified.

Design Data

COMMERCIAL FINNED TUBE CHARTS FOR RATING CORRECTIONS

For assistance with ratings and selection, please use our online Specifier.

CORRECTION FACTORS FOR WATER TEMPERATURES AND AIR TEMPERATURES OTHER THAN STANDARD															
AVERAGE WATER TEMP. °F	ENTERING AIR TEMPERATURE °F														
	45	55	STD 65	70	75	80	85	90	95	100	110	120	130	140	150
90	.19	.13	.11	.06											
100	.25	.19	.15	.11	.08	.06									
110	.31	.25	.20	.16	.13	.11	.08	.06							
120	.38	.31	.26	.21	.19	.16	.13	.11	.08	.06					
130	.45	.38	.33	.28	.25	.21	.19	.16	.13	.11	.06				
140	.53	.45	.40	.34	.31	.28	.25	.21	.19	.16	.11	.06			
150	.61	.53	.45	.41	.38	.34	.31	.28	.25	.21	.16	.11	.06		
160	.69	.61	.53	.49	.45	.41	.38	.34	.31	.28	.21	.16	.11	.06	
170	.77	.69	.61	.57	.53	.49	.45	.41	.38	.34	.28	.21	.16	.11	.06
180	.86	.77	.69	.65	.61	.57	.53	.49	.45	.41	.34	.28	.21	.16	.11
190	.95	.86	.78	.73	.69	.65	.61	.57	.53	.49	.41	.34	.28	.21	.16
200	1.05	.95	.86	.82	.77	.73	.69	.65	.61	.57	.49	.41	.34	.28	.21
210	1.14	1.05	.95	.91	.86	.82	.77	.73	.69	.65	.57	.49	.41	.34	.28
▶ 215 (STD.)	1.19	1.09	1.00	.95	.91	.86	.82	.77	.73	.69	.61	.53	.45	.38	.31
220	1.24	1.14	1.05	1.00	.95	.91	.86	.82	.77	.73	.65	.57	.49	.41	.34
230	1.34	1.24	1.14	1.09	1.05	1.00	.95	.91	.86	.82	.73	.65	.57	.49	.41
240	1.44	1.34	1.25	1.19	1.14	1.09	1.05	1.00	.95	.91	.82	.73	.65	.57	.49
250	1.55	1.44	1.34	1.29	1.24	1.19	1.14	1.09	1.05	1.00	.91	.82	.73	.65	.57
260	1.66	1.55	1.44	1.39	1.34	1.29	1.24	1.19	1.14	1.09	1.00	.91	.82	.73	.65
270	1.76	1.66	1.55	1.50	1.44	1.39	1.34	1.29	1.24	1.19	1.09	1.00	.91	.82	.73
280	1.87	1.76	1.66	1.60	1.55	1.50	1.44	1.39	1.34	1.29	1.19	1.09	1.00	.91	.82
290	1.99	1.87	1.76	1.71	1.66	1.60	1.55	1.50	1.44	1.39	1.29	1.19	1.09	1.00	.91
300	2.10	1.99	1.87	1.82	1.76	1.71	1.66	1.60	1.55	1.50	1.39	1.29	1.19	1.09	1.00

CORRECTION FACTORS FOR STEAM PRESSURES AND AIR TEMPERATURES OTHER THAN STANDARD																
STEAM		ENTERING AIR TEMPERATURE °F														
PRESSURE		TEMP. °F	45	55	STD 65	70	75	80	85	90	100	110	120	130	140	150
GAUGE	ABS. PSI															
(VAC) 15" HG	7.32	178.9	0.90	0.80	0.70	0.65	0.60	0.56	0.51	0.45	0.39	0.32	0.25	0.18	0.13	0.08
(VAC) 10"	9.78	192.2	1.02	0.91	0.81	0.76	0.71	0.66	0.62	0.55	0.48	0.40	0.33	0.26	0.20	0.14
(VAC) 5"	12.25	202.9	1.11	1.00	0.90	0.85	0.79	0.75	0.70	0.63	0.56	0.48	0.40	0.33	0.27	0.20
▶ 0 PSI	14.696	212.0	1.19	1.09	0.97	0.92	0.87	0.82	0.77	0.70	0.63	0.54	0.46	0.38	0.31	0.25
.899	15.595	215.0	1.22	1.11	1.00	0.95	0.90	0.84	0.80	0.75	0.65	0.57	0.48	0.40	0.33	0.26
5	19.70	227.1	1.34	1.22	1.11	1.05	1.00	0.95	0.90	0.81	0.75	0.66	0.57	0.49	0.41	0.34
10	24.70	239.4	1.45	1.33	1.22	1.17	1.11	1.05	1.00	0.91	0.85	0.75	0.66	0.58	0.50	0.42
15	29.70	249.8	1.55	1.43	1.31	1.26	1.20	1.14	1.09	1.00	0.94	0.84	0.75	0.66	0.57	0.49
20	34.70	258.5	1.63	1.52	1.40	1.33	1.28	1.23	1.17	1.07	1.02	0.92	0.82	0.73	0.64	0.55
25	39.70	266.8	1.71	1.59	1.47	1.41	1.36	1.30	1.25	1.15	1.09	0.98	0.89	0.80	0.71	0.62
30	44.70	274.0	1.78	1.66	1.54	1.48	1.42	1.37	1.31	1.21	1.15	1.05	0.95	0.85	0.76	0.68
40	54.70	286.7	1.91	1.79	1.66	1.61	1.54	1.49	1.43	1.32	1.27	1.16	1.06	0.97	0.87	0.78
50	64.70	297.7	2.02	1.90	1.77	1.71	1.65	1.60	1.54	1.42	1.37	1.26	1.16	1.06	0.96	0.87
60	74.70	307.3	2.10	2.00	1.87	1.81	1.75	1.69	1.63	1.51	1.47	1.35	1.25	1.15	1.05	0.95
70	84.70	316.0	2.20	2.09	1.95	1.89	1.83	1.77	1.71	1.59	1.55	1.44	1.33	1.23	1.12	1.03
80	94.70	323.9	2.27	2.17	2.03	1.97	1.91	1.85	1.80	1.69	1.63	1.52	1.41	1.31	1.20	1.10
90	104.70	331.2	2.36	2.24	2.11	2.05	1.98	1.93	1.87	1.74	1.70	1.59	1.48	1.38	1.28	1.17
100	114.70	337.9	2.43	2.31	2.18	2.11	2.05	2.00	1.94	1.81	1.77	1.65	1.54	1.44	1.33	1.23
125	139.70	352.9	2.59	2.47	2.33	2.27	2.21	2.16	2.10	1.96	1.92	1.80	1.69	1.59	1.48	1.38
150	164.70	365.9	2.73	2.62	2.47	2.43	2.35	2.29	2.23	2.08	2.05	1.94	1.82	1.72	1.61	1.51
175	189.70	377.4	2.86	2.74	2.60	2.54	2.47	2.41	2.35	2.21	2.17	2.05	1.95	1.85	1.73	1.63
200	214.70	387.8	2.95	2.85	2.71	2.63	2.58	2.52	2.47	2.31	2.29	2.17	2.06	1.96	1.84	1.75

From Keenan and Keyes — Linear Interpolation. NOTE: Gauge pressure should be corrected for altitude.

Rate of pitch for steam ½" drop over 20-foot run.

Design Data

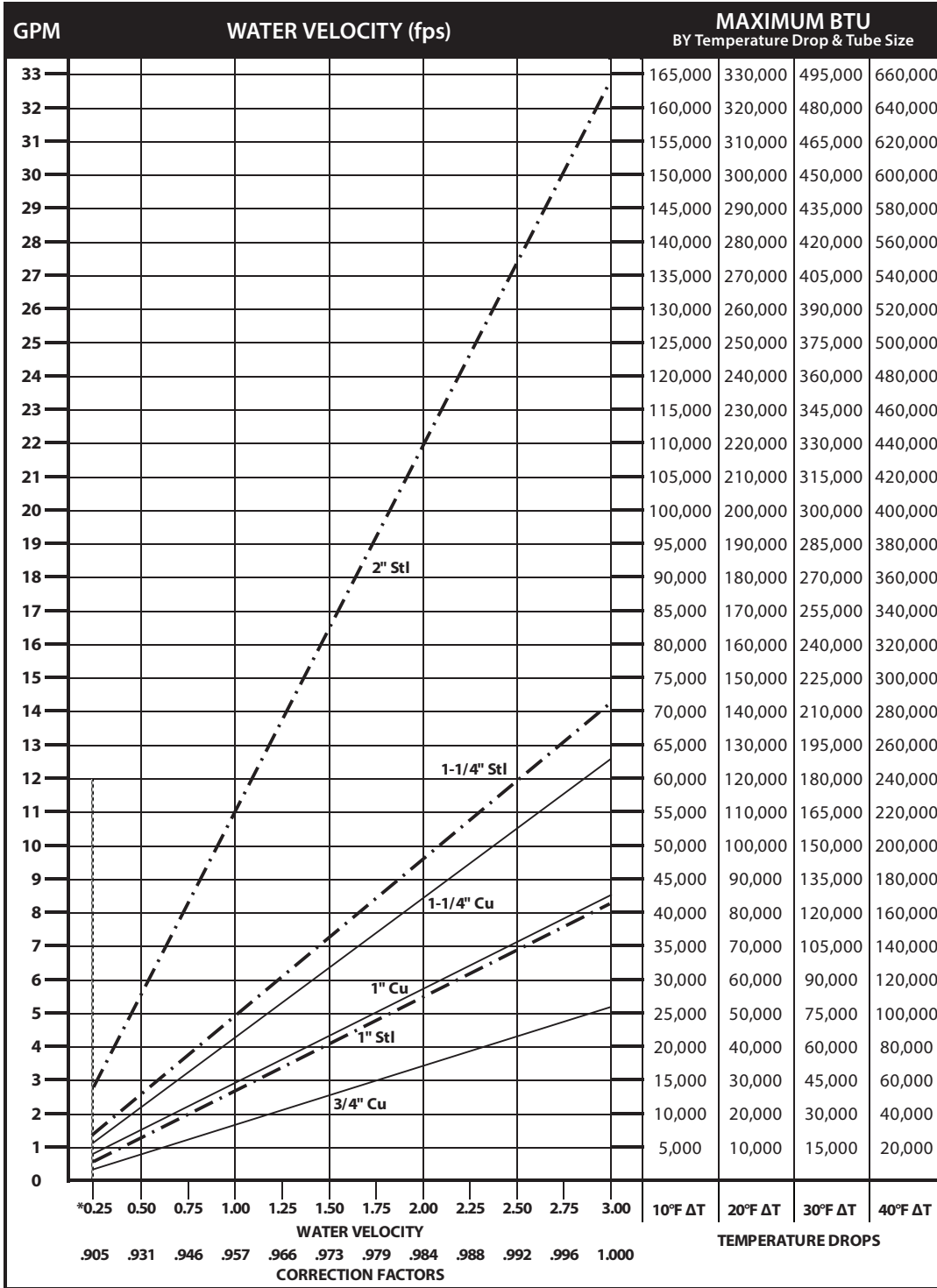

*Do not design below .25 fps.

DYNAMIC FORMULAS

$$BTU = GPM \times 500 \times TD$$

$$GPM = \left(\frac{BTU}{500} \right) \div TD$$

$$TD = \left(\frac{BTU}{500} \right) \div GPM$$

Pressure Drop at Given Water Velocities (Feet of Water per 100 ft. of pipe) based on Hazen - Williams calculation

Nominal Pipe Size	Water Velocity (ft/sec)											
	0.25	0.50	0.75	1.00	1.25	1.50	1.75	2.00	2.25	2.50	2.75	3.00
3/4" Copper	0.06	0.20	0.42	0.72	1.09	1.53	2.04	2.61	3.25	3.95	4.71	5.53
1" Copper	0.04	0.15	0.32	0.54	0.81	1.14	1.52	1.94	2.42	2.94	3.50	4.11
1 1/4" Copper	0.03	0.12	0.25	0.43	0.64	0.90	1.20	1.54	1.92	2.33	2.78	3.26
1" Steel	0.04	0.15	0.32	0.54	0.81	1.14	1.52	1.95	2.42	2.94	3.51	4.12
1 1/4" Steel	0.03	0.11	0.23	0.40	0.60	0.84	1.12	1.44	1.79	2.17	2.59	3.05
2" Steel	0.02	0.07	0.14	0.25	0.37	0.52	0.69	0.89	1.10	1.34	1.60	1.88

Design Data

GUARANTEED WORKING PRESSURES

- 1" IPS – 780 at Temperatures up to 650°F.
- 1-1/4" IPS – 660 at Temperatures up to 650°F.
- 2" IPS – 405 at Temperatures up to 650°F.
- 1-1/4" CU – 194 at Temperatures up to 300°F.
- 1" CU 204 at Temperatures up to 300°F.
- 3/4" CU 218 PSI at Temperatures up to 300°F.

MAXIMUM PRESSURES AT OTHER TEMPERATURES
ARE AVAILABLE UPON REQUEST.

Pipe Water Capacities and Quantities Circulated at Velocity of 3 Feet Per Second

Nominal Pipe Size	Pipe I.D. (inches)	Gals Per Lin. Ft.	GPM @ 3' per sec Velocity
3/4" Copper	0.835	0.028	5.12
1" Copper	1.077	0.047	8.52
1 1/4" Copper	1.315	0.071	12.70
1" Steel	1.075	0.047	8.49
1 1/4" Steel	1.395	0.079	14.29
2" Steel	2.115	0.183	32.85

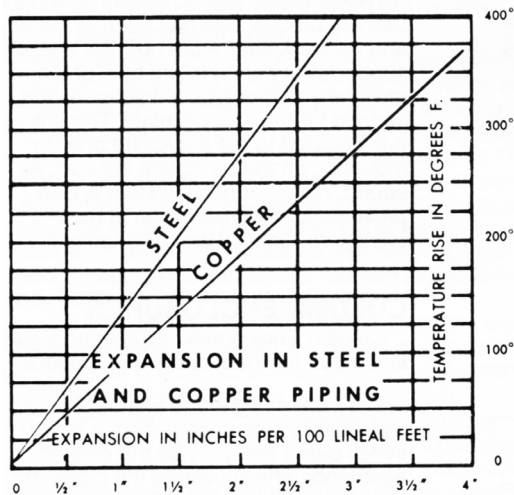

Glycol Correction Factors

Fluid Temperature 200°F

% Solution	Ethylene Glycol	Propylene Glycol
20	.952	.988
30	.921	.968
40	.888	.943
50	.852	.912

Fluid Temperature 180°F

% Solution	Ethylene Glycol	Propylene Glycol
20	.946	.982
30	.913	.961
40	.879	.934
50	.842	.902

Fluid Temperature 140°F

% Solution	Ethylene Glycol	Propylene Glycol
20	.934	.97
30	.898	.946
40	.861	.916
50	.821	.881

INLET VS. OUTPUT/BTUH CAPACITY REDUCTION

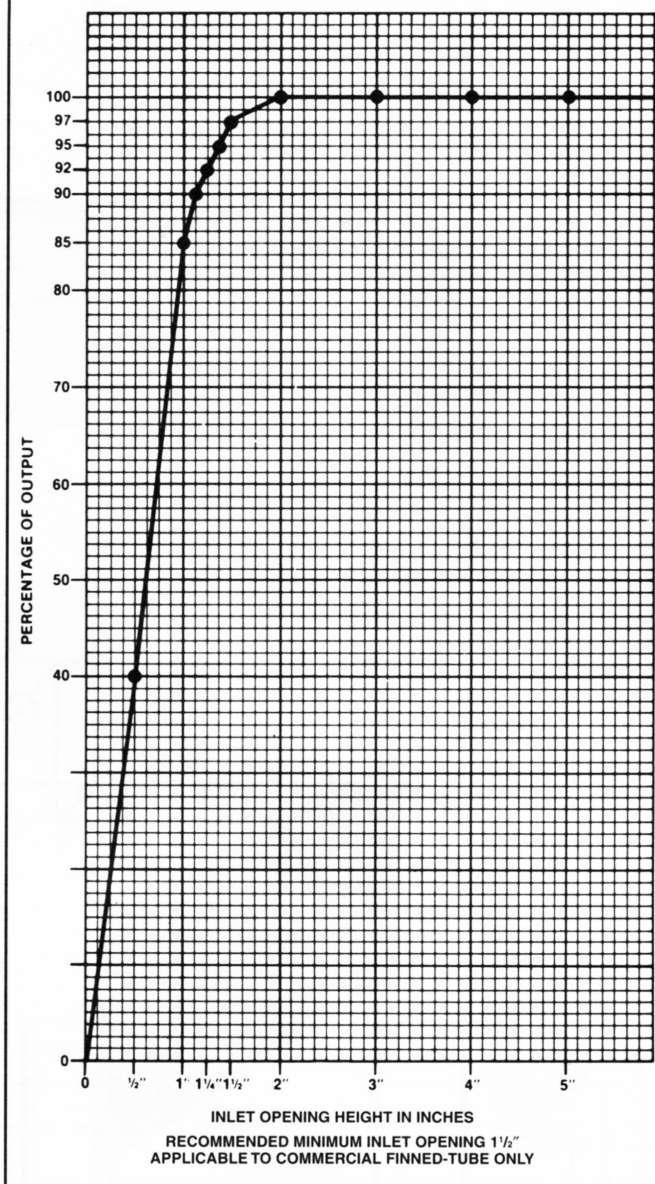

ALTITUDE FACTORS

Approximate factors for convective heat value at varying altitudes

Altitude	Ferrous Units	Copper Alum. Units
Sea Level	1.000	1.000
1,000 ft.	.984	.969
2,000 ft.	.968	.938
3,000 ft.	.952	.908
4,000 ft.	.936	.878
5,000 ft.	.920	.850
6,000 ft.	.904	.822
7,000 ft.	.889	.795
8,000 ft.	.874	.768
9,000 ft.	.859	.743
10,000 ft.	.844	.718
15,000 ft.	.771	.603
20,000 ft.	.703	.502